

# Prop Guard®

## Installation Instructions

**Time required: About 25-30 minutes. Don't be in a hurry!**

Tools needed: Drill, 5/16" bit, 1/2" box end or socket wrench, C-clamps or Grip clamps.

**4 ea. 5/16"x 1" Bolts**  
on 9" & 11" PROP GUARD®

**6 ea. 5/16"x 1" Bolts**  
on 13"&14" (On 16" PROP

GUARD® use 8 ea 1 1/4" Bolts  
Cavitation  
Plate

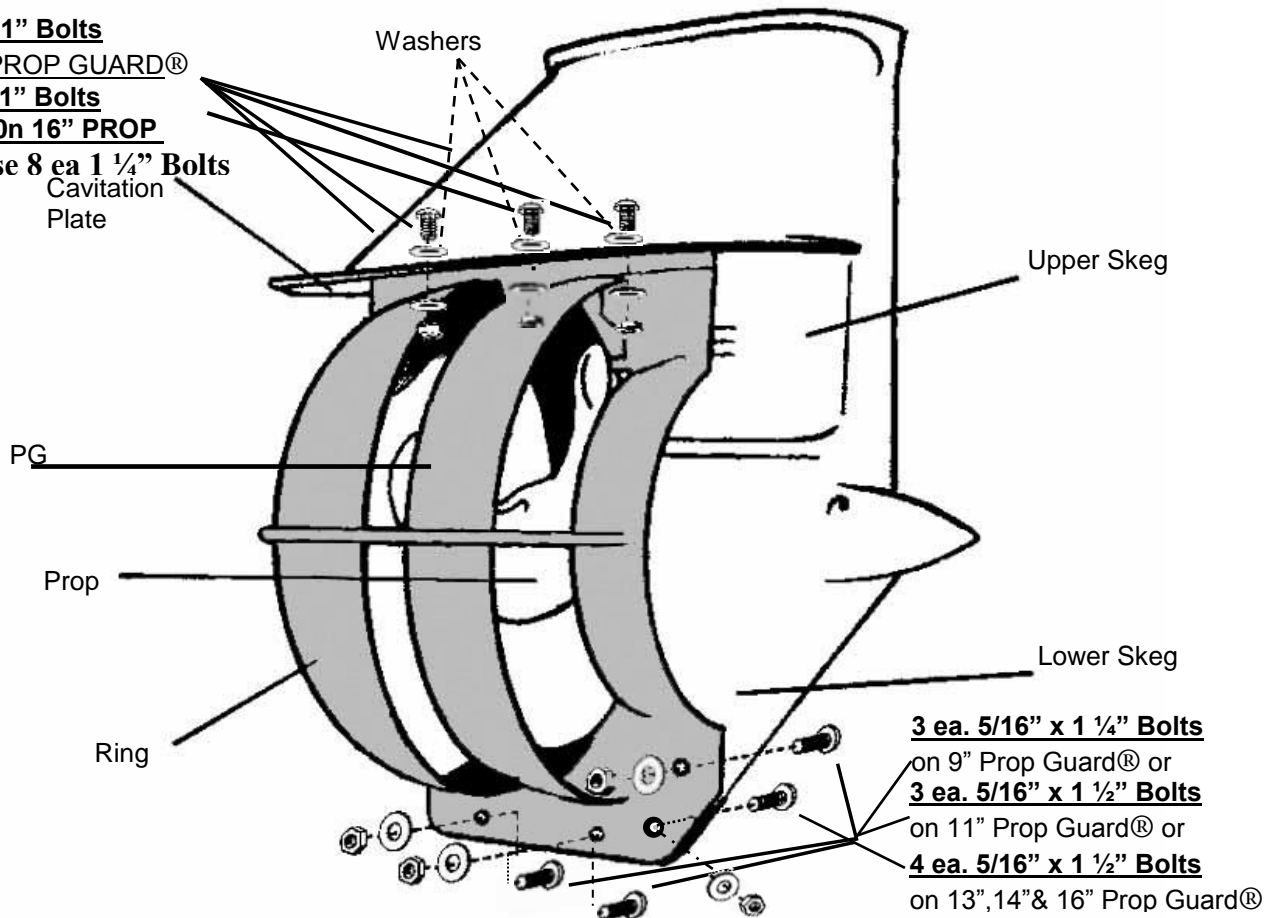

1. Place the Prop Guard® on the **underside** of the cavitation plate. Align the guard so that equal distance exists between the guard and the prop when the propeller revolves inside the guard. The Prop Guard® should be positioned as far forward on the cavitation plate as possible. Note: the mounting surface of the guard should remain flat against the cavitation plate. The use of a hand file may be needed to remove any imperfections in the lower surface of the cavitation plate and the lower skog. **REMOVE TRIM TAB FIN UNDER CAVITATION PLATE. INSTALLATIONS OF 13" & 14" MUST NOT EXCEED 25MPH AT THIS TIME.**
2. Clamp the guard to the underside of cavitation plate using C-clamps or Grip clamps. Insert bolts, washers and Nyloc nuts through bottom of pre-drilled holes at bottom of rings and loosely tighten.
3. Make certain that the guard is square with the cavitation plate, propeller and lower skog. **PROPELLER MUST BE SURROUNDED BY THE PROP GUARD. MAY NEED TO SLIDE PROP GUARD (PG) FORWARD OR AFT FOR PROPER PROP CLEARANCE.**
4. Drill 2, 3 or 4 (see chart Above) holes through the cavitation plate and guard on each side. Insert bolts, washers (on each side of bolts) and Nyloc nuts as illustrated and loosely tighten.
5. Drill 1 to 2 (see chart above) holes through lower skog, per illustration. Insert bolt, washer and Nyloc nut, tighten securely. Now tighten all your bolts. **REMOVE CLAMPS !!!**
6. **EXTREMELY IMPORTANT: MAKE SURE YOUR MOTOR IS TRIMMED TO OBTAIN MAXIMUM PERFORMANCE OF YOUR PROP GUARD® .**

**PROP GUARD MARINE, INC., P.O. Box 630, Westcliffe, CO 81252**