



For Pumps and Parts
go to PumpVendor.com

Model 17830-Series

Model 17830-Series

OIL CHANGE PUMP

FEATURES

- Body:** Bronze
- Impeller:** Nitrile
- Seal:** Buna Lip Type
- Motor:** Reversible Permanent Magnet with Integral Reversing Switch
- Valve:** 3/8" NPT Full Flow Ball Type
- Height:** 4-7/16" (113mm) Including Height of Switch Guard
- Length:** 7-7/8" (200mm)
- Width:** 3-3/4" (95mm)
- Weight:** 9 lb. (4.1 kg)
- Rating:**  and EMC Compliant



VARIATIONS AVAILABLE

MODEL NO.	DESCRIPTION
17830-0012	12 Volt
17830-0024	24 Volt

APPLICATION

The Jabsco Oil Change Pump is designed to be installed near a vessel's engine and permanently plumbed to the engine's oil pan. The pump can be used to remove old oil from the engine, then with the integral reversing switch, the flow direction can be changed to pump a measured amount of new oil back into the engine. The connection to the engine should be controlled by the 3/8" ball valve (provided) to guard against accidental oil discharge.



WARNING Caution—Burn Hazard. Heated oil can cause burns. Wear protective gloves, clothing and safety glasses during the oil change process. Failure to do so may result in personal injury.

OPERATION

Before changing oil, run engine about 3–5 minutes to raise the oil temperature to about 100° – 140° F (38° – 60° C) and reduce its viscosity. Open the security valve in the oil change system. Ensure the waste oil discharge hose is securely positioned in a waste oil receptacle (be aware that during the pumping process the discharge hose may tend to move slightly) and switch the pump on by moving the toggle switch in the direction that the oil needs to flow. Once the pumping process is complete (flow has stopped), switch the pump off immediately. Do not allow the pump to run dry for more than about thirty

seconds or impeller damage may occur. Using the engine's dipstick; verify that it is in fact empty and the oil flow was not stopped by sludge. If the engine oil is empty, a measured amount of the correct type (per the engine manufacturer's recommendation) of new oil can be pumped back into the engine. Insert what was the discharge hose, and for refilling purposes becomes the intake suction hose, into a container with the measured amount of oil. Move the pump's toggle switch in the direction of desired flow toward the engine and pump the measured amount of oil into it. When the container is empty immediately turn off the pump. Close the system security valve and always check the oil level with the engine's dipstick to ensure the oil level is correct.

INSTALLATION

The Oil Change Pump may be oriented in any position. However, if mounted to a vertical surface, it should be oriented with the pump's motor above the pump head. This will ensure that, should the seal ever develop a leak, oil from the pump head will not drip onto the motor. The Oil Change Pump should be located where the length of hose to the engine can be kept as short and straight as possible. The pump is self-priming and may be positioned up to three feet above the oil source. However, for best operation the pump should be mounted at a level that is just slightly above the highest oil level to be changed. Often this is approximately even with the level of the engine mounts. Secure the pump to a solid mounting surface at the four base attachment points. It is recommended that heavy duty reinforced type A fuel hose be used to connect the pump with the engine pan. The hose assembly should be made with permanent type end connector fittings similar to hose assemblies for on-board natural or propane gas systems.

WIRING

The pump should be wired to an overload protected electrical distribution panel (circuit breaker or fuse panel) with marine grade copper stranded wire, sized to match the recommendation in the Electrical Specifications chart. The electrical circuit breaker (or fuse) must also be sized to match the Electrical Specifications recommendation. Connect the motor's orange wire lead to positive and the black lead to negative. Make all connections with mechanical locking type connectors such as crimp type butt connectors. Once the wiring is completed, the electrical wires should be secured to a solid surface every eighteen inches along the length of their run to prevent movement and abrasion.

WIRE SIZE (AWG [mm²]) for various conductor lengths

Model Number	Amp Volts	Fuse/ Draw	Brkr.	Length of run in feet (meters)*			
				0-10(0-3)	10-20(3-6)	20-30(6-9)	30-50(9-15)
17830-0012	12	10	15	16(1.5)	14(2.5)	12(4)	10(6)
17830-0024	24	5	8	16(1.5)	16(1.5)	16(1.5)	16(1.5)

* The length of run is the total length of both positive and negative conductors measured from the positive power source to the pump and back to negative.

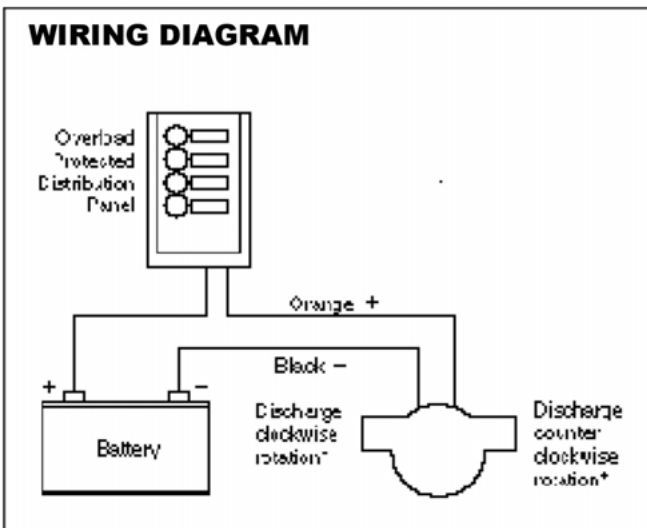

SERVICE

The Jabsco Oil Change Pump should provide many years of reliable service without the need for regular or scheduled maintenance. However, if sludge should become lodged anywhere in the system, it can cause excessive vacuum or pressure on the pump that may damage the flexible impeller. If this occurs pump performance will be reduced and it will become necessary to change the pump's impeller.

Before performing any service work, ensure the system's security valve is closed and the power to the pump is turned off and labeled "Do Not Turn On" to guard against it being accidentally turned back on while service work is being performed.

IMPELLER REPLACEMENT

To change the impeller, remove the pump end cover screws, end cover and O-ring. Grasp the impeller's hub with a pair of pliers and pull the old impeller from the impeller bore.

With a rotary motion (to flex the blades of the new impeller under the cam silhouette in the pump body) push the new impeller into the body until the flat of the impeller insert aligns with the flat of the shaft. When the two flats align, push the impeller firmly into the impeller bore until it bottoms in the bore. Place the end cover O-ring seal in the O-ring groove in the body. (A small amount of grease may be used to hold it in place.) Position the end cover against the body and secure it with the end cover screws.

SEAL REPLACEMENT

Under normal circumstances, the shaft seal should function properly for several hundred hours of operation. If the seal should ever develop a leak and need to be replaced, begin the procedure by following the above instructions for changing an impeller. Once the impeller has been removed, remove the two screws that secure the pump head to the motor and pull the pump body off of the motor shaft. Using a piece of 1/2" wood dowel (or similar material) from the back (motor) side of the body push against the seal to dislodge it from the seal bore. When the seal is removed, ensure the seal bore is clean of all debris. From the front (impeller) side of the pump housing, place the new seal in the seal bore, ensuring the lip of the seal is pointing toward the impeller bore and press the seal into the seal bore until it is firmly seated in the bottom of it. Guide the motor shaft through the lip seal and resecure the pump body to the motor end bell. With this complete, the impeller, O-ring and end cover can be re-installed per the above instructions for impeller replacement.

EXPLODED VIEW

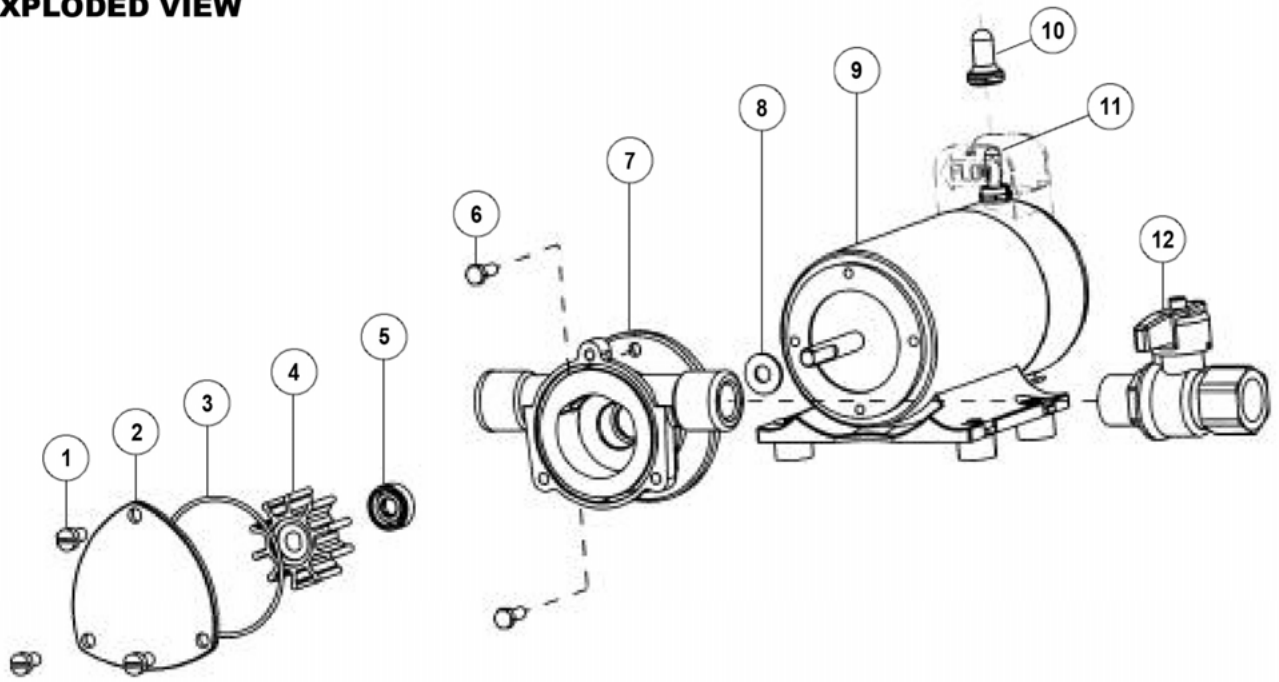

PARTS LIST

Key	Description	Part No.
1	Screw Kit (includes 4 screws)	91004-0090
2	End Cover	18647-0000
3	O-Ring	18753-0660
4	Impeller	9200-0023
5	Seal	18753-0384
6	Screw Kit (includes 3 screws)	98019-0020
7	Body	18646-0000
8	Slinger	6342-0000
9	Motor: 12 Volt, EMC	18753-0067
	24 Volt, EMC	18753-0636
10	Toggle Switch Boot	98022-0000
11	Switch Polarity Reversing	18753-0652
12	Ball Valve 3/8"	98024-0002

DIMENSIONAL DRAWING

Inches (Millimeters)

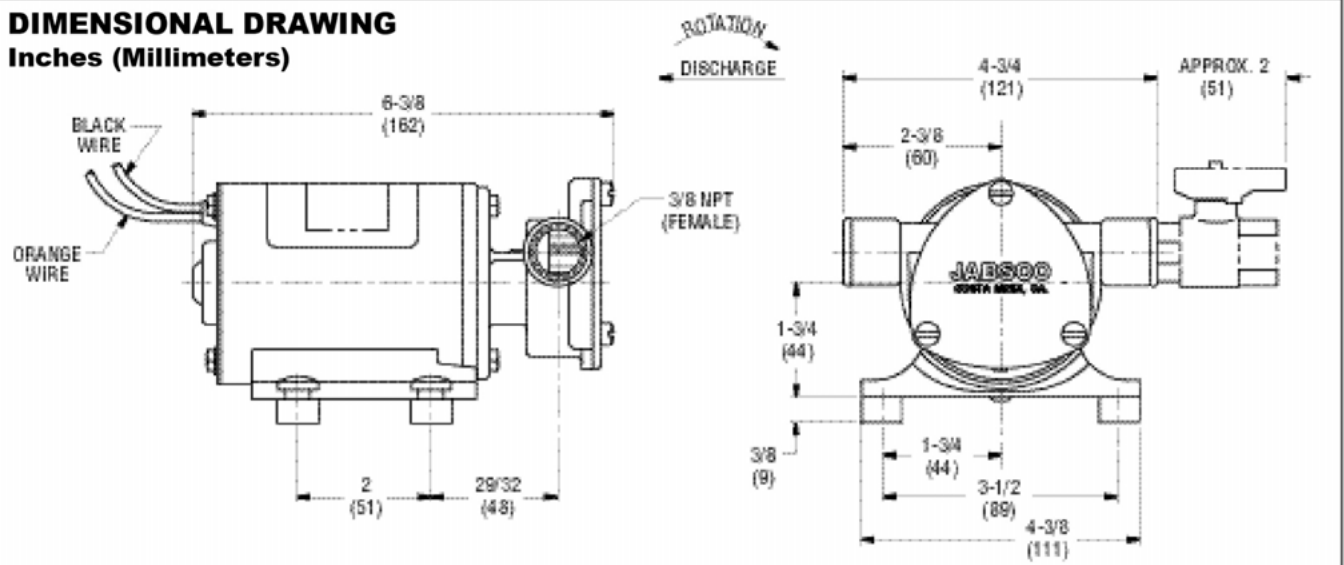

ONE YEAR LIMITED WARRANTY

A. LIMITED WARRANTY:

Jabsco warrants that at the time of shipment, the products manufactured by Jabsco and sold hereunder shall be in conformity with applicable written specifications and descriptions referred to or set forth herein, free from defects in material and, merchantable, and suitable for a particular purpose, provided such is implied by State law under the circumstances of this sale.

B. WARRANTY ADJUSTMENT:

1. Jabsco agrees to repair or furnish a replacement for, but not to remove or install, any product or component thereof which, within one (1) year from date of purchase, shall upon test and examination by Jabsco prove defective within the above warranty. Receipt verifying purchase date is required to obtain adjustment.
2. Buyer shall notify Jabsco of any defect within this warranty no later than ninety (90) days after the defect is discovered.
3. No product will be accepted for return or replacement without the prior written authorization of Jabsco. Upon such authorization, and in accordance with instructions from Jabsco, the product will be returned to Jabsco, shipping charges prepaid by Buyer. Products returned to Jabsco will be addressed as follows:

JABSCO

1485 Dale Way

Costa Mesa, California 92626-3998

Or to such alternate locations as may be designated on the product, its container, or this sheet.
Repair or replacement made under this warranty will be shipped prepaid to Buyer.

C. EXCLUSIONS FROM WARRANTY AND LIMITATION OF LIABILITY:

1. The foregoing warranty is limited solely as set forth herein and applies only for the period designated above.

2. JABSCO SHALL NOT BE LIABLE FOR ANY LOSS, DAMAGE, SPECIAL OR CONSEQUENTIAL DAMAGE OF ANY KIND, WHETHER BASED UPON WARRANTY, CONTRACT, NEGLIGENCE, OR STRICT LIABILITY ARISING IN CONNECTION WITH THE SALE, USE, OR REPAIR OF THE PRODUCT.
3. THE MAXIMUM LIABILITY OF JABSCO IN CONNECTION WITH THIS WARRANTY SHALL NOT IN ANY CASE EXCEED THE CONTRACT PRICE FOR THE PRODUCT CLAIMED TO BE DEFECTIVE OR UNSUITABLE.
4. This warranty does not extend to any product manufactured by Jabsco which has been subjected to misuse, neglect, accident, improper installation, or use in violation of instructions furnished by Jabsco.
5. This warranty does not extend to or apply to any unit which has been repaired or altered at any place other than Jabsco's factory, or by persons not expressly approved by Jabsco, nor to any unit the serial number, model number, or identification of which has been removed, defaced or changed.
6. Components manufactured by any supplier other than Jabsco shall bear only that warranty made by the manufacturer of that product.
7. This warranty applies to products defined as "consumer products" by the Consumer Product Warranties Act as from time to time amended.

D. CONSUMER RIGHTS:

This warranty gives you specific legal rights, and you may have other rights which vary from state to state. Some states do not allow exclusion or limitation of damages.

STANDARD WARRANTY: If the products manufactured and sold hereunder are not Consumer Products, the warranty extended to Buyer shall be as set forth in subparagraphs (A), (B), and (C), **EXCEPT THAT ALL EXPRESS OR IMPLIED WARRANTIES OR MERCHANTABILITY OR SUITABILITY FOR ANY PARTICULAR PURPOSE ARE EXCLUDED.**

Jabsco



ITT Industries
Engineered for life

U.S.A.
Jabsco
20 Icon
Foothill Ranch, CA 92610-3000
Tel: 949.609.5106
Fax: 949.859.1254

UNITED KINGDOM
Jabsco
Bingley Road, Hoddesdon
Hertfordshire EN11 0BU
Tel: +44 (0) 1992 450145
Fax: +44 (0) 1992 467132

CANADA
Fluid Products Canada
55 Royal Road
Guelph, Ontario N1H 1T1
Tel: (519) 821.1900
Fax: (519) 821.2569

JAPAN
NHK Jabsco Company Ltd.
3-21-10, Shin-Yokohama
Kohoku-Ku, Yokohama, 222
Tel: 045.475.8906
Fax: 045.475.8908

GERMANY
Jabsco GmbH
Oststrasse 28
22840 Norderstedt
Tel: +49-40-53 43 73 -0
Fax: +49-40-53 53 73 -11